



# MILITARY COTS

## CONFIGURABLE MULTI-OUTPUT SINGLE PHASE AC-DC POWER SUPPLY

<b>1 to 2 Outputs</b> Standard Configurations	<b>85 - 180 Vrms</b> Input Voltage	<b>47 - 63 Hz / 360 - 800 Hz</b> Input Frequency	<b>Up to 650 W</b> Total Output Power
--	---------------------------------------	---	--

The MultiQor Plate format of input-filtered single phase AC-DC power supplies provides up to two customer defined output voltages that are isolated from the input, each other and the cold plate. Using SynQor’s Mil-COTS line of high efficiency, high reliability, fixed switching frequency DC-DC converters, PFC and EMI filters, this supply is designed to comply with MIL-STD-704, and MIL-STD-1399. The complete assembly is designed to withstand the harsh environments of the Military and Aerospace industries and is compliant with MIL-STD-810G requirements.

### MultiQor™ Single Phase AC-DC Power Supply



#### Operational Features

- Input voltage range: 85 - 180 Vrms
- Universal input frequency range: 47 - 63 Hz / 360 - 800 Hz
- Up to 650 W output power
- ≥ 0.99 Power Factor (50/60 Hz)
- Internal inrush current limit
- Hold-Up Capacitors (with available external connection)

#### Compliance Features

- Designed to meet these standards:
- MIL-STD-461
    - CE101 ▪ CE102 ▪ RE101 ▪ RE102
    - CS101 ▪ CS106 ▪ CS114 ▪ CS115 ▪ CS116
  - MIL-STD-1399
  - MIL-STD-704-2, -704-4, & -704-6\* (see 704 app section)

#### Mechanical Features

- Size: 6.70" x 9.12" x 1.23" (170.2 x 231.6 x 31.3 mm)
- Refer to mechanical diagrams for weight
- Cold plate with mounting holes for connection to heat removal system

#### Control Features

- PFC Enable (isolated)
- Individual output voltage Enable control (isolated)
- AC Power Good Signal (isolated)

#### Safety Features

- Input/Output to baseplate isolation 2150 Vdc
- Internal input fuses

#### Protection Features

- Input current limit and auto-recovery short circuit protection
- Auto-recovery input under/over-voltage protection
- Auto-recovery output over-voltage protection
- Auto-recovery thermal shutdown

#### Contents

	Page No.
Configurations .....	2
Standards & Qualification Testing .....	9
Mechanical Drawings P1 .....	10
Mechanical Drawings P2 .....	11
Accessory Information.....	12
Ordering Information .....	13



## CONFIGURATIONS

### P1 SINGLE OUTPUT

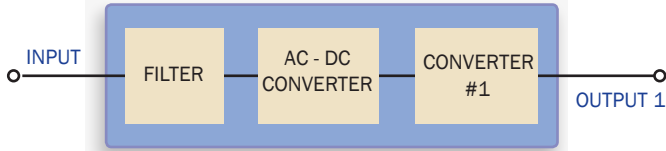

### P1 CONVERTER OPTIONS:

- Any Full-Brick or Half-Brick converter from the MCOTS-270 Family
- Size: 6.70" x 9.12" x 1.23"
- Typical Weight: 3.4 LB to 3.7 LBS (1 HB or 1 FB)

### P2 DUAL OUTPUT

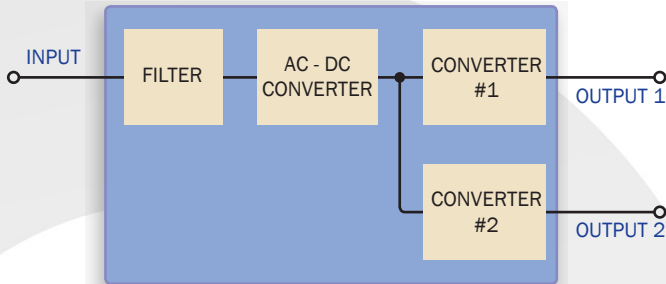

### P2 CONVERTER OPTIONS:

- Any two Half-Brick converters from the MCOTS-270 Family
- Size: 6.70" x 9.12" x 1.23"
- Typical Weight: 3.7 LBS (2 HB)



# MTQ-Px-AC115-1 Family Input Characteristics

Parameter Min. Typ. Max. Units Notes & Conditions

ABSOLUTE MAXIMUM RATINGS					
<b>Input Voltage</b>					
Continuous			450	Vpk	
Non-operating 100ms Transient			575	Vpk	
<b>Isolation Voltage</b>					
			2150	Vdc	Input/Output to Plate
			2850	Vdc	Input to Output
<b>Operating Temperature</b>	-55		100	°C	Plate Temperature
<b>Storage Temperature</b>	-55		125	°C	
ELECTRICAL CHARACTERISTICS					
<b>Operating Input Voltage Range</b>					
AC Input Continuous	85		180	Vrms	
AC Input 100ms Transient	40		180	Vrms	See Note 1
<b>Operating Input Frequency</b>					
	47		63	Hz	50/60 Hz range
	360		800	Hz	400 Hz range
<b>Power Factor of AC Input Current</b>					
		0.99			50/60 Hz range
		0.97			400 Hz range, min 400 W output, See Note 2
<b>Total Harmonic Distortion of AC Input Current</b>		3		%	At full output power
<b>Inrush of AC Input Current</b>					
			10	Apk	50/60 Hz range
			20	Apk	400 Hz range
<b>Maximum Input Power</b>			775	W	
<b>Maximum Input Current</b>			9.5	Arms	85 VAC in
<b>Input Under-Voltage Lockout</b>		30		Vrms	>1s Duration, See Note 1
<b>On-Board Hold-up Capacitance</b>		440		µF	20% tolerance
FEATURE CHARACTERISTICS					
<b>Operating Aux Input Voltage Range</b>	6		24	V	
<b>Maximum Input Current on Aux IN</b>			10	mA	
<b>PFC Enable Control</b>					
					Pin 6 of J2, referenced to AGND, See Note 3
PFC Off-State Voltage	-0.7		0.7	V	
PFC On-State Voltage	2.5		40	V	
<b>Converter Enable Control</b>					
					Pins 3 & 8 of J2, referenced to AGND, See Note 3
Converter Off-State Voltage	-0.7		0.7	V	
Converter On-State Voltage	2.5		40	V	

**Note 1:** Available output power reduced when <85 Vrms, see Figure 1

**See individual DC-DC Converter and Filter Datasheets for more information regarding performance specifications, (MACF-xxx-230-HT, MPFC-115-270-HP, MCOTS-C-270-xx-FT, MCOTS-C-270-xx-HT).**

**Note 2:** For better performance below -40C, uses external capacitors as necessary

**Note 3:** The MTQ can be optioned to permanently enable the PFC and Converters

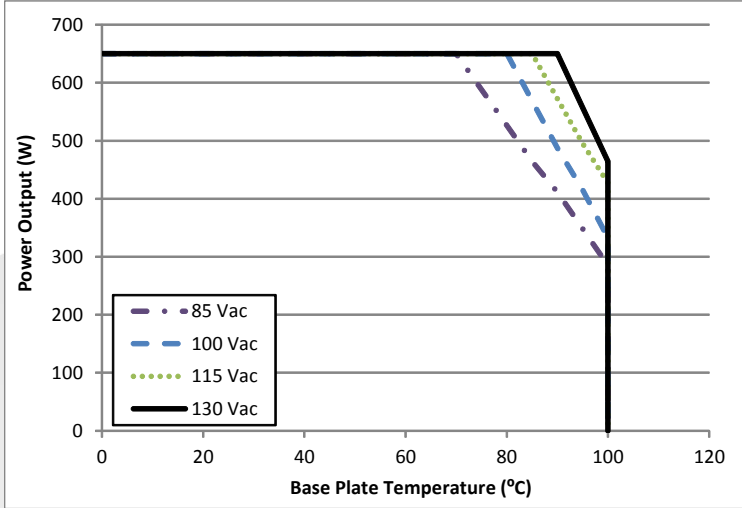

*Figure 1: Typical output power vs. baseplate temperature derating curve. Refer to MPFC-115-270-HP and the converter's datasheet for specific derating.*



## BLOCK DIAGRAM FOR P1

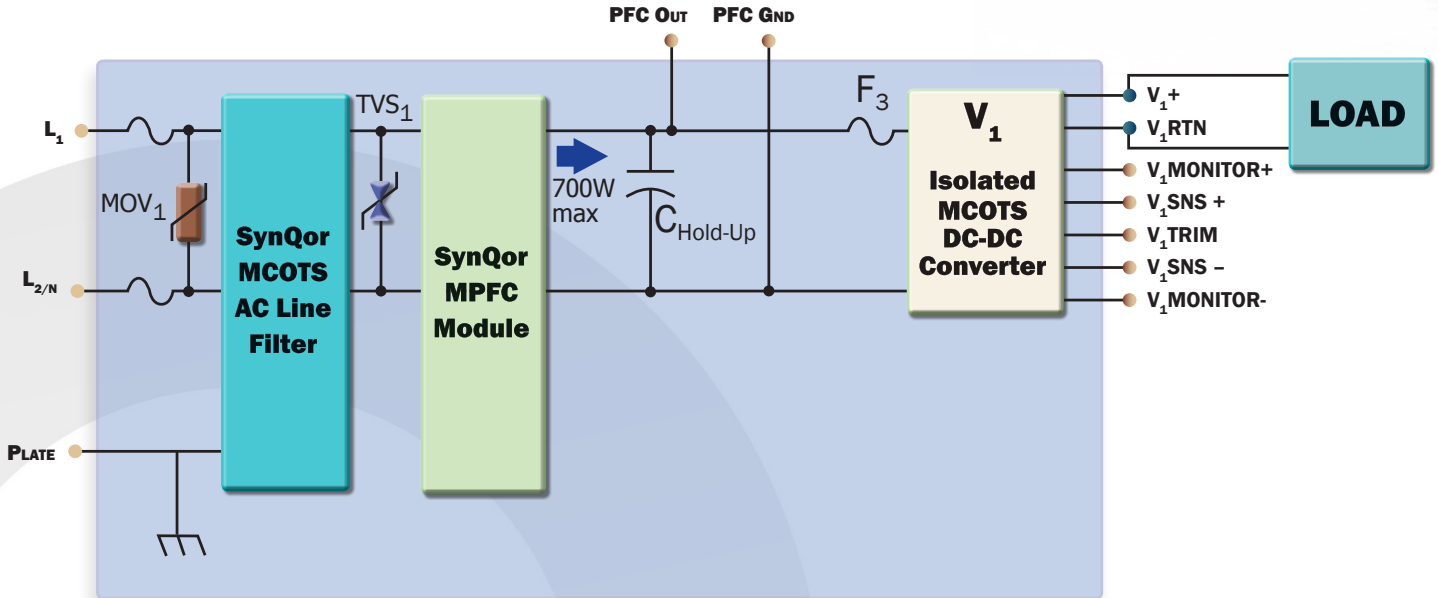

**Note:** Maximum total output power must be limited such that the power drawn from the PFC is typically  $\leq 700W$ . The efficiency of each converter should be considered in this calculation.

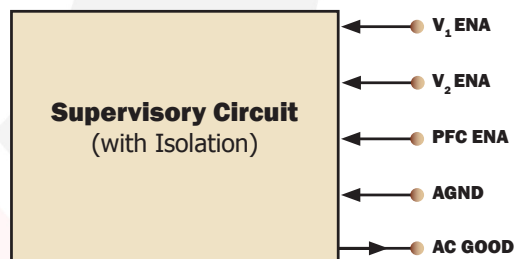



## BLOCK DIAGRAM FOR P2

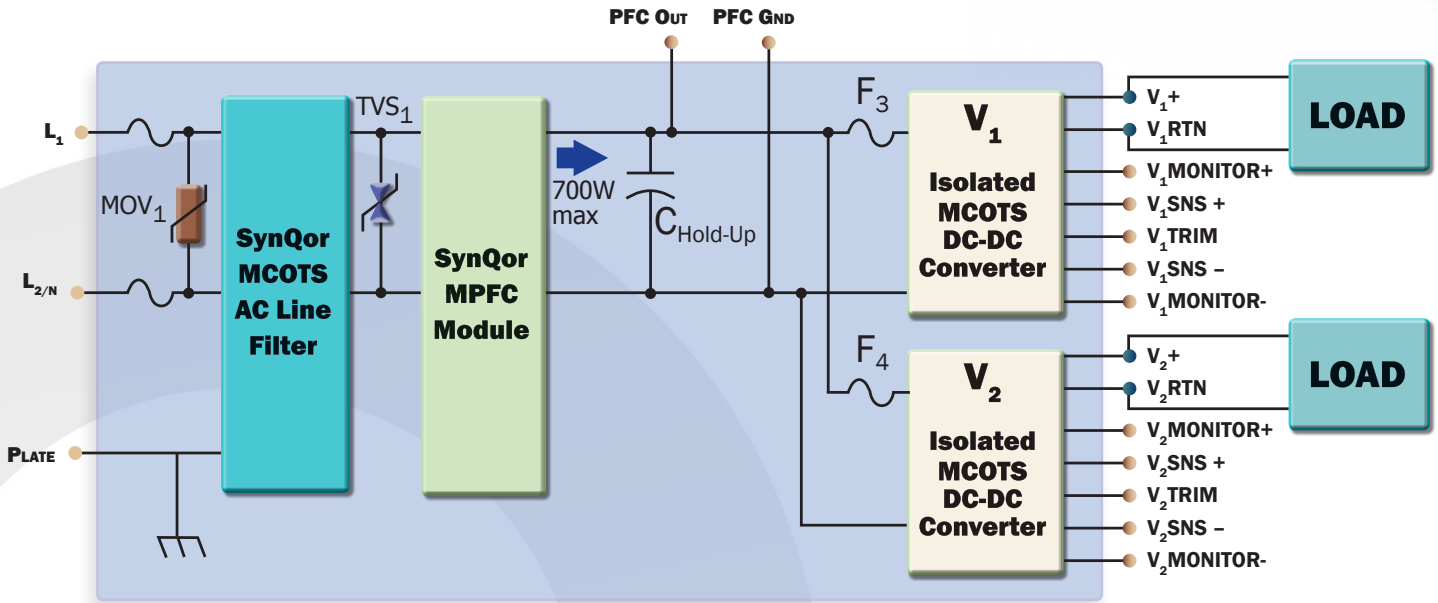

**Note:** Maximum total output power must be limited such that the power drawn from the PFC is typically  $\leq 700W$ . The efficiency of each converter should be considered in this calculation.

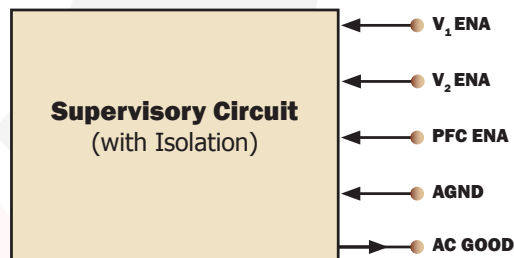



## MultiQor Control Circuitry Features

The MTQ-Px-AC115-1 has control feature signals available on the connector, J2, which are isolated from the input and output of the system.

### Auxiliary Power In

The MTQ-Px-AC115 requires an external DC voltage to operate the controls. The operating range is 6-24 VDC. This voltage is applied on Pin 2 and referenced to AGND on Pin 1. Refer to Figure A.

### PFC Enable Control

The PFC Enable Control Pin toggles the PFC Output (270 VDC) ON and OFF. The PFC Output, which is not isolated to the AC input, is the external hold-up capacitance connection on J11. The PFC output feeds the DC-to-DC converters so disabling will also disable the output(s) of the system. The PFC Enable control pin is Pin 6. To turn on the PFC output, Pin 6 must be pulled high in reference to AGND on Pin 1. Refer to Figure B. Optional: PFC Enable Control can be permanently removed so a signal is not required and the PFC is always enabled.

### Converter Enable Controls:

The MTQ-Px-AC115 has two configurations for converter enable control. P1 uses Pin 8 to toggle the DC-to-DC converter output ON and OFF. P2 uses Pin 8 for converter 1 and Pin 3 for converter 2, independently of each other. To turn the converter outputs on, the converter enable signals must be pulled high in reference to AGND on Pin 1. Refer to Figure C. Optional: Converter Enable Control(s) can be permanently removed so a signal is not required and the converters are always enabled.

### AC GOOD:

The AC\_GOOD signal is internally pulled low whenever the AC source voltage is within the PFC's continuous operating range for at least one cycle of the source waveform, regardless of whether the PFC is enabled or disabled. Refer to Figure D.

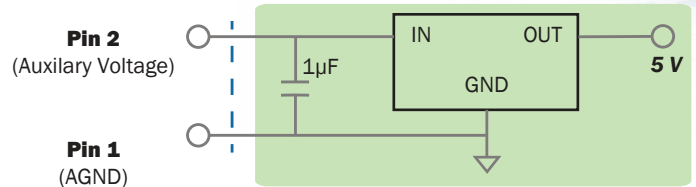

Figure A: An equivalent circuit looking into Auxiliary Power In.

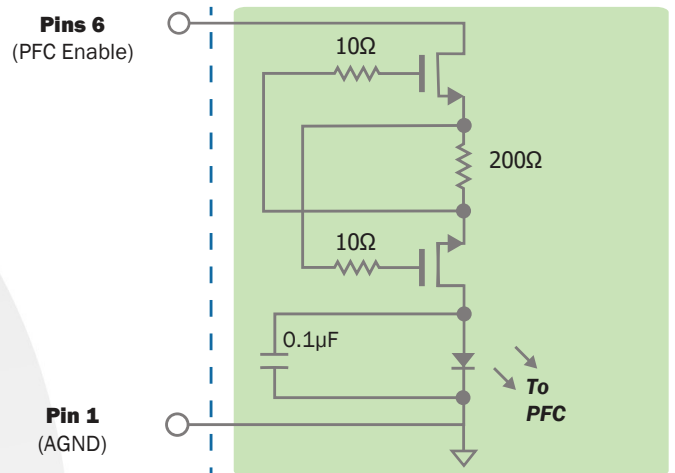

Figure B: An equivalent circuit looking into PFC Enable Control.

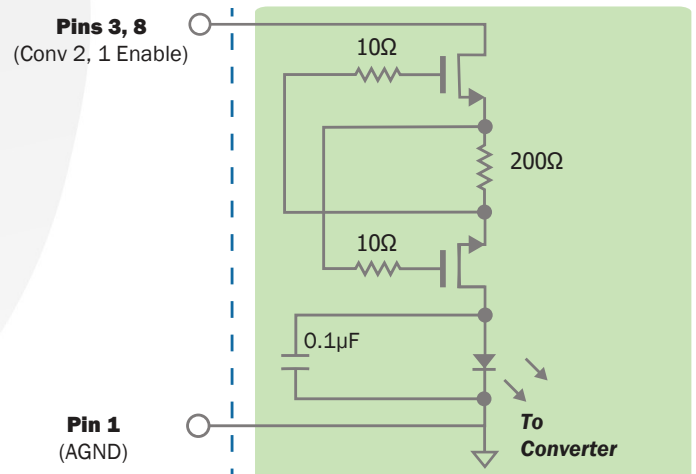

Figure C: An equivalent circuit looking into Converter Enable Control.

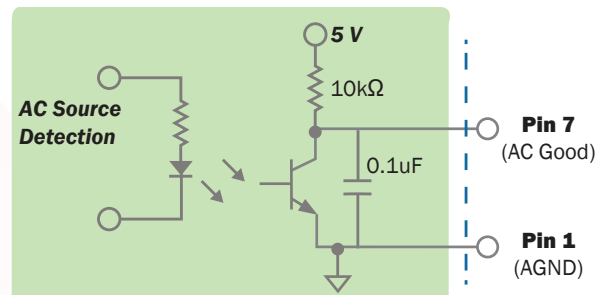

Figure D: An equivalent circuit looking into the AC Good.



**MultiQor™**  
**MTQ-Px-AC115-1**

**CONVERTERS LISTED BY VOUT**

**Available MCOTS-C-270 DC-DC Converters**

Half-Brick Tera Series (MCOTS-C-270-xx-HT)							
Vout	3.3	5.0	12.0	15.0	24.0	28.0	48.0
Power	198 W	250 W	300 W	300 W	300 W	300 W	302 W
Output Current	60 A	50 A	25 A	20 A	12.5 A	10.7 A	6.3 A
Efficiency @270Vin (Full Load)	0.86	0.87	0.87	0.88	0.90	0.90	0.89
Ripple & Noise (pk to pk)	120 mV	100 mV	72 mV	151 mV	120 mV	190 mV	350 mV
Output OVP Setpoint No Load	4.1 V	6.18 V	15.0 V	18.88 V	30.0 V	35.0 V	60.0 V
No Load Input Current	50 mA	43 mA	44 mA	48 mA	37 mA	49 mA	49 mA

Full-Brick Tera Series (MCOTS-C-270-xx-FT)							
Vout		5.0	12.0	15.0	24.0	28.0	48.0
Power		400 W	600 W	600 W	600 W	599 W	600 W
Output Current		80 A	50 A	40 A	25 A	21.4 A	12.5 A
Efficiency @270Vin (Full Load)		0.88	0.91	0.91	0.91	0.91	0.91
Ripple & Noise (pk to pk)		200 mV	136 mV	150 mV	300 mV	220 mV	540 mV
Output OVP Setpoint No Load		6.3 V	15.0 V	18.8 V	30.0 V	35.0 V	60.0 V
No Load Input Current		30 mA	35 mA	30 mA	49 mA	35 mA	30 mA

Full-Brick Peta Series (MCOTS-C-270H-xx-FP)							
Vout		5.0	6.0	7.0	28.0	36.0	
Power		500 W	660 W	630 W	800 W	800 W	
Output Current		100 A	110 A	90 A	28.6 A	22.2 A	
Efficiency @270Vin (Full Load)		0.86	0.87	0.89	0.91	0.91	
Ripple & Noise (pk to pk)		215 mV	215 mV	215 mV	375 mV	400 mV	
Output OVP Setpoint No Load		6.25 V	7.5 V	8.75 V	35 V	45 V	
No Load Input Current		49 mA	100 mA	100 mA	49 mA	49 mA	

Full power operation at -55 °C to +100 °C, designed for Mil-COTS applications.



## STANDARDS & QUALIFICATION TESTING

### MIL-COTS DC-DC Converter and Filter Qualification

Test Name	Details	# Tested (# Failed)	Consistent with MIL-STD-883F Method	Consistent with MIL-STD-883F Method 5005
<b>Life Testing</b>	Visual, mechanical and electrical testing before, during and after 1000 hour burn-in @ full load	15 (0)	Method 1005.8	
<b>Shock-Vibration</b>	Visual, mechanical and electrical testing before, during and after shock and vibration tests	5 (0)		MIL-STD-202, Methods 201A & 213B
<b>Humidity</b>	+85 °C, 95%RH, 1000 hours, 2 minutes on/6 hours off	8 (0)	Method 1004.7	
<b>Temperature Cycling</b>	500 cycles of -55 °C to +100 °C (30 minute dwell at each temperature)	10 (0)	Method 1010.8	Condition A
<b>Solderability</b>	15 pins	15 (0)	Method 2003	
<b>DMT</b>	-65 °C to +110 °C across full line and load specifications in 5 °C steps	7 (0)		
<b>Altitude</b>	70,000 feet (21 km), see Note	2 (0)		

Note: A conductive cooling design is generally needed for high altitude applications because of naturally poor convective cooling at rare atmospheres.

### MIL-COTS DC-DC Converter and Filter Screening

Screening	Process Description	S-Grade	M-Grade
<b>Baseplate Operating Temperature</b>		-55 °C to +100 °C	-55 °C to +100 °C
<b>Storage Temperature</b>		-65 °C to +135 °C	-65 °C to +135 °C
<b>Pre-Cap Inspection</b>	IPC-610, Class III	Yes	Yes
<b>Temperature Cycling</b>	Method 1010, Condition B, 10 Cycles		Yes
<b>Burn-In</b>	100 °C Baseplate	12 Hours	96 Hours
<b>Final Electrical Test</b>	1	25 °C	-55 °C, +25 °C, +100 °C
<b>Final Visual Inspection</b>	MIL-STD-2008	Yes	Yes

### MTQ-Px-AC115-1 Assembly Qualification

Environment Tests	Process Description	Details	Specification
<b>Vibration</b>	Method 514.6	Procedure I	20G's (0.2 g2/Hz); 10-2000Hz
<b>Shock/Drop</b>	Method 516.6	Procedure I	40G's (11ms); 75G'speak (6ms); Sawtooth Pulse



## MECHANICAL DRAWINGS P1

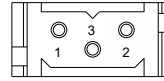
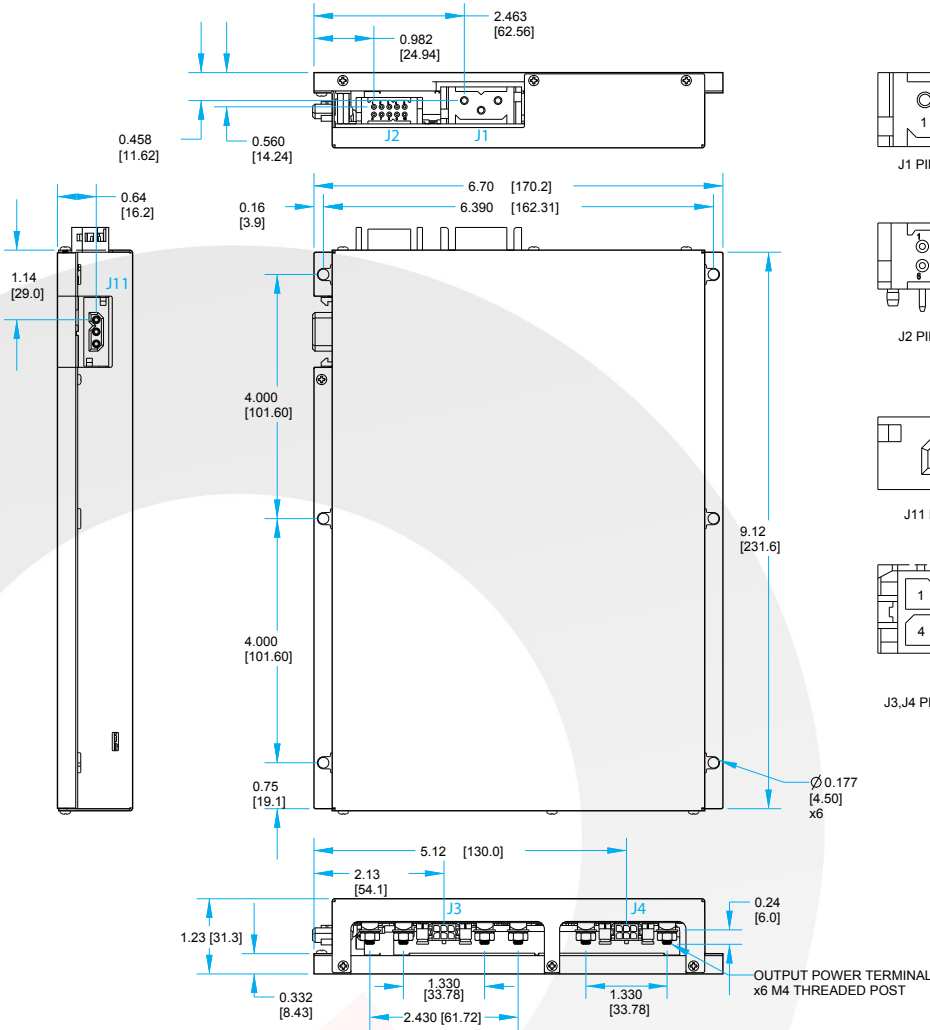

J1 PIN LOCATIONS

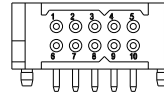

J2 PIN LOCATIONS

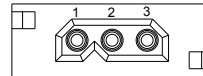

J11 PIN LOCATIONS

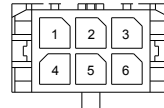

J3,J4 PIN LOCATIONS

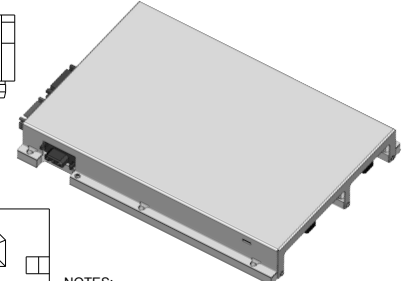

### NOTES:

- ALL DIMENSIONS IN INCHES [MM]
- TOLERANCES: X.XX± 0.02 IN [±0.5MM]  
X.XXX± 0.010 IN [±0.25MM]
- CONNECTOR PART NUMBERS:  
J1 POSITRONICS PLB3W3M4BN0A1/AA  
J2 POSITRONICS DF10M4BN/AA  
J11 POSITRONICS PLA03F4BN0A1  
J3,J4 MOLEX 430450606
- WEIGHT: 3.4lb TO 3.7lb (1HB or 1FB/2HB)
- MOUNT UNIT USING (6) 8-32 OR M4 MACHINE SCREWS AND FLAT WASHER .02-.04 [5-1.0MM] THICK.
- TORQUE SPEC FOR MOUNTING HOLES AND OUTPUT TERMINALS, 6IN-LBS.

### Hold-Up Connector (J11)

Pin	Name	Function
1	PFC GND	Negative Output of PFC
2	NC	Not Connected
3	PFC OUT	Positive Output of PFC

### Input Connector (J1)

Pin	Name	Function
1	COM IN	Chassis
2	L1	AC Line 1
3	L2/N	AC Line 2 / Neutral

### Output Connector (J3)

Pin	Name	Function
1	MONITOR+	Monitor of Vout+
2	NC	Not Connected
3	MONITOR-	Monitor of Vout-
4	VSENSE+	Sense Positive
5	TRIM	Trim Pin
6	VSENSE-	Sense Negative

### Input Signal Connector (J2)

Pin	Name	Function
1	AGND	Analog Ground
2	AUX IN	Aux Power In [Ref to AGND]
3	NC	Not Connected
4	NC	Not Connected
5	NC	Not Connected
6	PFC ENA	PFC Enable [Ref to AGND]
7	AC GOOD	Ref to AGND
8	CONV 1 ENA	Converter 1 Enable [Ref to AGND]
9	NC	Not Connected
10	NC	Not Connected

### MECHANICAL DRAWINGS P2

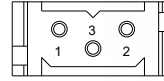
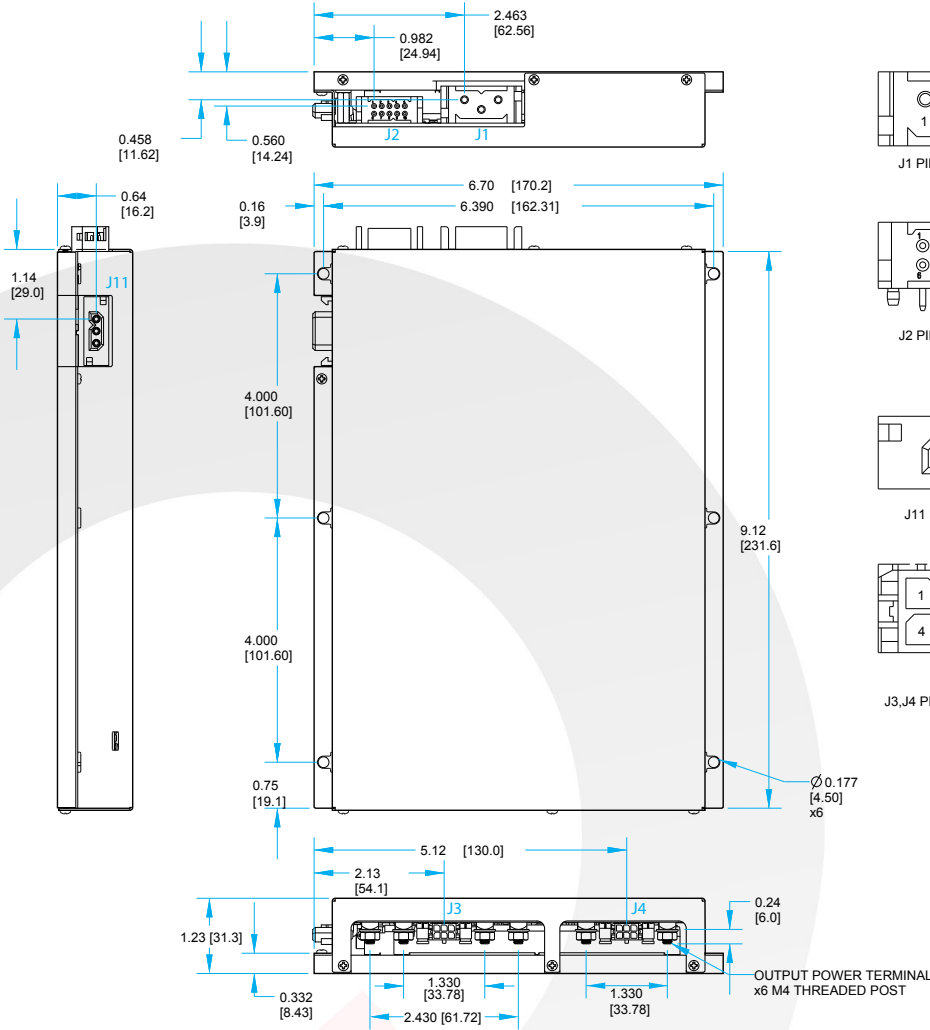

J1 PIN LOCATIONS

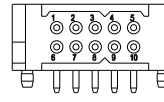

J2 PIN LOCATIONS

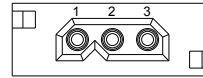

J11 PIN LOCATIONS

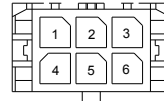

J3,J4 PIN LOCATIONS

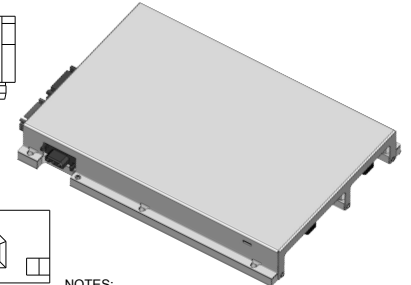

**NOTES:**

1. ALL DIMENSIONS IN INCHES [MM]
2. TOLERANCES: X.XX± 0.02 IN [±0.5MM]  
X.XXX± 0.010 IN [±0.25MM]
3. CONNECTOR PART NUMBERS:  
J1 POSITRONICS PLB3W3M4BN0A1/AA  
J2 POSITRONICS DF10M4BN/AA  
J11 POSITRONICS PLA03F4BN0A1  
J3,J4 MOLEX 430450606
4. WEIGHT: 3.4lb TO 3.7lb (1HB or 1FB/2HB)
5. MOUNT UNIT USING (6) 8-32 OR M4 MACHINE SCREWS AND FLAT WASHER .02-.04 [-5-1.0MM] THICK.
6. TORQUE SPEC FOR MOUNTING HOLES AND OUTPUT TERMINALS, 6IN-LBS.

**Hold-Up Connector (J11)**

Pin	Name	Function
1	PFC GND	Negative Output of PFC
2	NC	Not Connected
3	PFC OUT	Positive Output of PFC

**Input Connector (J1)**

Pin	Name	Function
1	COM IN	Chassis
2	L1	AC Line 1
3	L2/N	AC Line 2 / Neutral

**Output Connector (J3, J4)**

Pin	Name	Function
1	MONITOR+	Monitor of Vout+
2	NC	Not Connected
3	MONITOR-	Monitor of Vout-
4	VSENSE+	Sense Positive
5	TRIM	Trim Pin
6	VSENSE-	Sense Negative

**Input Signal Connector (J2)**

Pin	Name	Function
1	AGND	Analog Ground
2	AUX IN	Aux Power In [Ref to AGND]
3	CONV 2 ENA	Converter 2 Enable [Ref to AGND]
4	NC	Not Connected
5	NC	Not Connected
6	PFC ENA	PFC Enable [Ref to AGND]
7	AC GOOD	Ref to AGND
8	CONV 1 ENA	Converter 1 Enable [Ref to AGND]
9	NC	Not Connected
10	NC	Not Connected



## MultiQor Plate Cables

These cables can be used with MultiQor Plates and Adaptor Boards with multiple output options to accommodate different levels of output current.

Description	Part Number
Input mating cable with pre-stripped wire ends (36"), Hold Up	MTQ-CBL-ACCAP1
Input mating cable with pre-stripped wire ends (36"), AC Signal	MTQ-CBL-ACINPUTS1
Input mating cable with pre-stripped wire ends (36"), AC Power	MTQ-CBL-ACINPUTP1
Output signal mating cable with pre-stripped wire ends (36")	MTQ-CBL-OUT1CS
Output power mating cable (20A) with pre-stripped wire ends (36")	MTQ-CBL-OUT1CP20
Output power mating cable (40A) with pre-stripped wire ends (36")	MTQ-CBL-OUT1CP40
Output power mating cable (60A) with pre-stripped wire ends (36")	MTQ-CBL-OUT1CP60

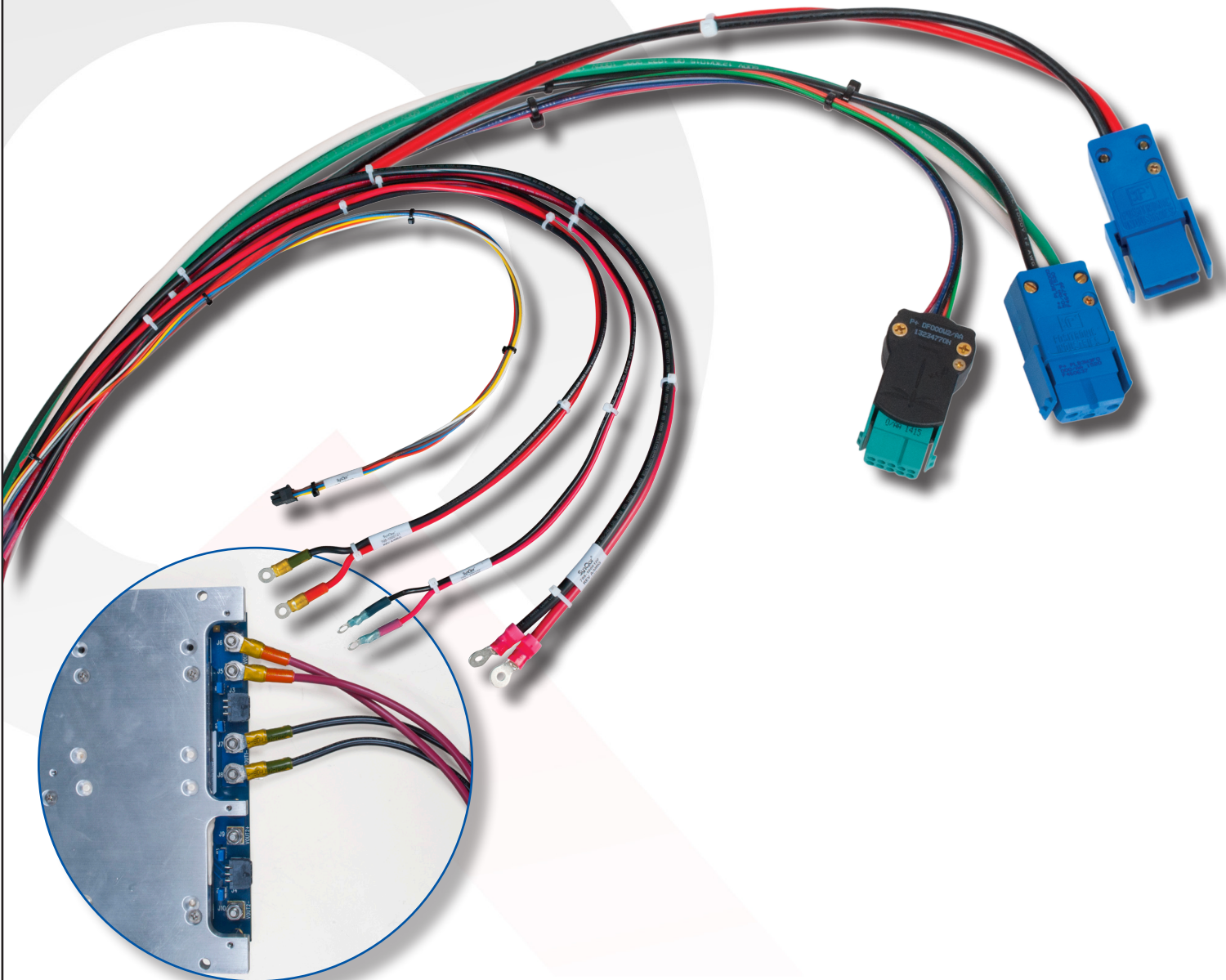



## Ordering Information / Part Numbering

<b>MTQ</b>	-	<b>P1</b>	-	<b>AC115</b>	-	<b>1</b>	-	<b>XXXXXX</b>	-	<b>S</b>	<b>V</b>
Family	-	Plate Format (# of Outputs)	-	Input Voltage Range	-	Phase	-	6 Digit Application Identification Number	-	Screening	
<b>MTQ</b>		<b>P1:</b> 1 output <b>P2:</b> 2 output		<b>AC115:</b> 85 - 180 Vrms		<b>1:</b> Single Phase		6 Digit Application Identification Number		<b>S:</b> S-Grade <b>M:</b> M-Grade	<b>V:</b> Cover

Not all combinations make valid part numbers, please contact SynQor to order a configured solution.

**Example: MTQ-P1-AC115-1-XXXXXX-SV**

### PART NUMBERING SYSTEM

The part numbering system for SynQor's ac-dc converters follows the format shown in the example.

### APPLICATION NOTES

A variety of application notes and technical white papers can be downloaded in pdf format from our website.

### Contact SynQor for further information and to order:

Phone: 978-849-0600 Fax: 978-849-0602  
 E-mail: [power@synqor.com](mailto:power@synqor.com) Web: [www.synqor.com](http://www.synqor.com)  
 Address: 155 Swanson Road, Boxborough, MA 01719 USA

### WARRANTY

SynQor offers a two (2) year limited warranty. Complete warranty information is listed on our website or is available upon request from SynQor.

### PATENTS

SynQor holds numerous U.S. patents, one or more of which apply to most of its power conversion products. Any that apply to the product(s) listed in this document are identified by markings on the product(s) or on internal components of the product(s) in accordance with U.S. patent laws. SynQor's patents include the following:

7,765,687 7,787,261  
 8,149,597 8,644,027